



FUJITEC

GS AUTOWALK 8100

GS8100-S

GS8100-F

GS8100-P



AUTOWALK (Horizontal / Inclined type)

Fujitec's user-friendly GS8100 autowalk serves passengers with its exceptional smoothness and quietness. Inclined type is also available.

User-friendliness

Superb riding comfort

Exceptional smoothness & quietness

High Quality



Variety of Types

| | | |
|----------------------|---|--|
| <p>Type-S</p> | <p>[Slim type] Interior panels are made of clear tempered glass which provides a sophisticated appearance.</p> <p>Indoor use.</p> | |
| <p>Type-F</p> | <p>[Frame type] (Lighting is option) Interior panels are made of clear tempered glass. Optional lighting under the handrails creates an elegant look.</p> <p>Indoor & Outdoor use.</p> | |
| <p>Type-P</p> | <p>[Panel type] Interior panels are made of hairline-finished stainless steel and are ideally suited for public transit systems.</p> <p>Indoor & Outdoor use.</p> | |

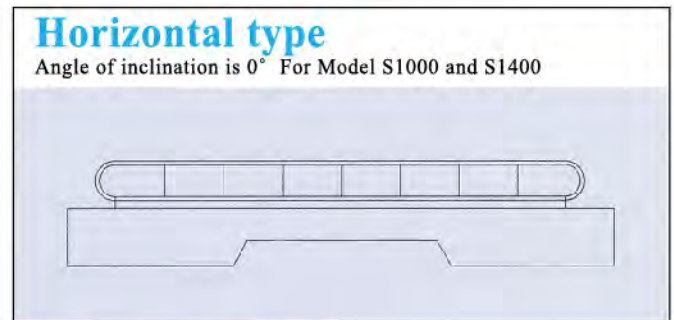
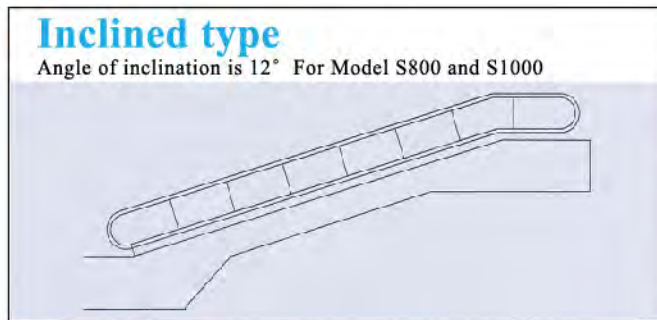

Specifications

●: Standard Spec. ■: Optional Spec.

| Balustrade | | |
|----------------------------|---|---|
| Handrail | Synthetic Rubber(black) | ● |
| | Polyurethane (black & 7 colors) | ■ |
| Handrail Frame | | |
| Deck Cover (Only S&F type) | Hairline-finished Stainless Steel | ● |
| Interior Panel | Type S & F: Colorless, Clear Tempered Glass | ● |
| | Type-P: Hairline-finished Stainless Steel | ● |
| Skirt Panel | Hairline-finished Stainless Steel | ● |
| | Stainless Steel with low friction coating | ■ |
| | Steel with low friction coating | ■ |
| Pallet | | |
| Tread | Aluminum Alloy Die-cast (gray) S800, S1000 | ● |
| | Stainless Steel S1400 | ● |
| | Aluminum Alloy Die-cast (gray)S1400 | ■ |
| Demarcation Line | Painted (yellow) [For Model S800 and S1000] Synthetic Resin (yellow) [For Model S1400] | ● |
| Floor Plate | | |
| Comb | Aluminum Alloy Die-cast | ● |
| Landing Plate | Aluminum | ● |
| | Hairline-finished Stainless Steel | ■ |

Basic Specifications

| Item | Model S800 | Model S1000 | Model S1400 |
|---|----------------------------|-------------|-------------|
| Pallet width (mm) | 800 | 1000 | 1400 |
| Max.length (m) | 100 (For Horizontal Type) | | |
| Max. vertical rise (m) | 9 (For Inclined Type) | | |
| Inclination (degrees) | 12° | 0° / 12° | 0° |
| Speed(m/min) | 30 | | |
| Transportation capacity (Passengers / hour) | 6750 | 9000 | 13500 |
| Power | 220V / 380V 60Hz | | |
| | 380V/400/V415V 50Hz | | |

Notes:

- 1)The above specifications are based on EN115.
- 2)The above specifications shall be changed according to the applied code.
- 3)Angle of inclination 0 is not applied for model S800.
- 4)Synthetic resin (yellow) demarcation line is standard for model S1400.

All Computer Graphics may differ from actual appearance.
Specifications and features are subject to change without notice.

Safety Devices

Fujitec's GS8100 series autowalk come with various safety devices designed with the priority concept of passenger's safety first.

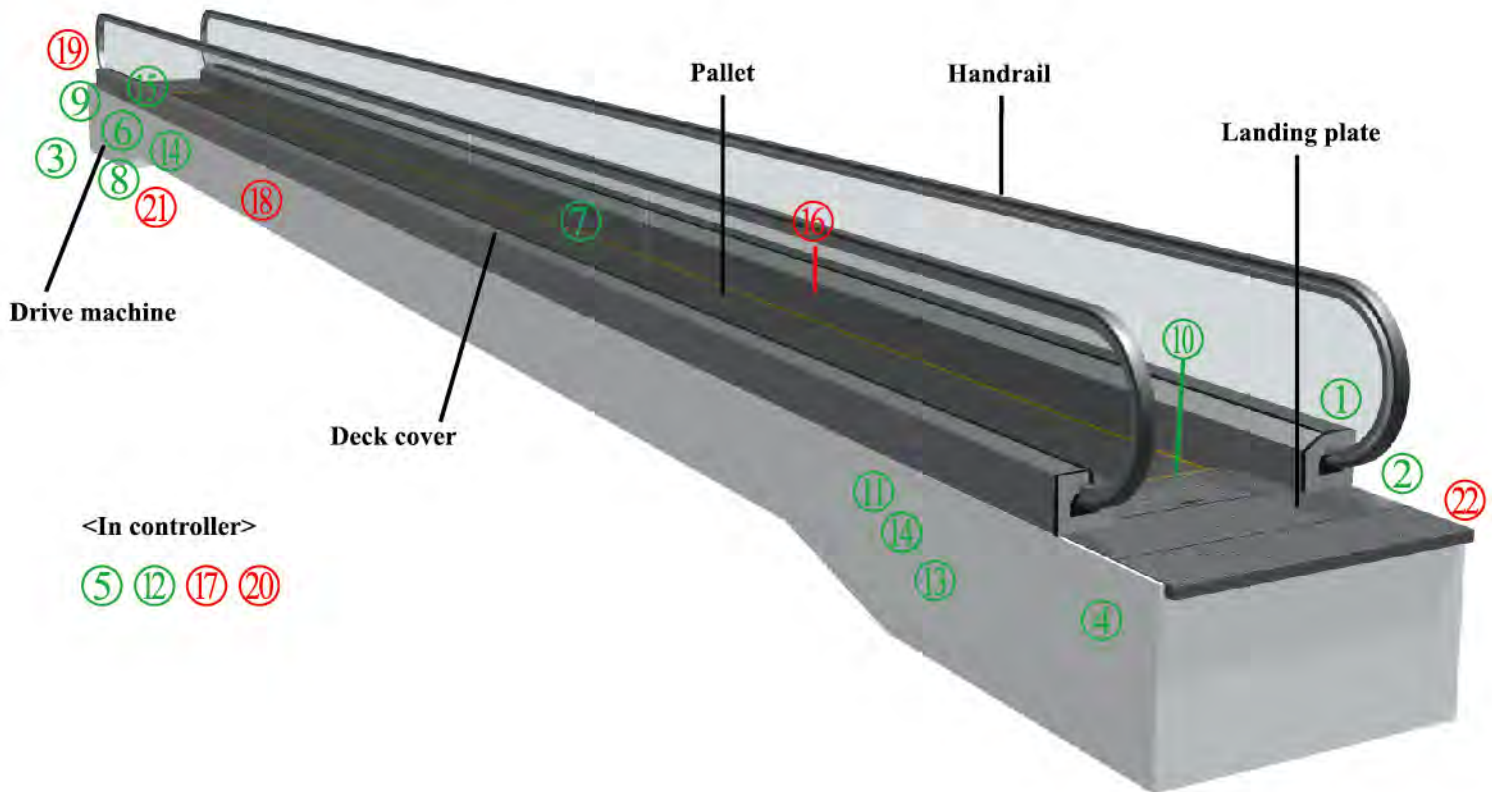

Standard safety devices

1. Handrail safety guard

Stops the autowalk when an object is caught in the handrail inlet.

2. Emergency stop button

Stops the autowalk when the button is pressed.

3. Broken drive-chain safety device

Stops the autowalk if the drive-chain is stretched or broken.

4. Broken pallet chain safety device

Stops the autowalk if the pallet chain is stretched excessively or broken.

5. Electric circuit protection device

Provided with an automatic circuit breaker to protect the autowalk circuitry and power supply parts.

6. Brake

Brake is activated to stop the autowalk by a spring force action when the power fails or any safety device is activated.

7. Demarcation line

Demarcation lines at both sides of pallet are painted yellow.

8.Reversal protection device

Stops the autowalk when reverse operation against the preset direction is commanded.(For inclined autowalk only)

9.Governor

Should the autowalk go in overspeed or in a opposite direction against the preset direction, the operation is stopped. (For inclined autowalk only)

10.Comb safety device

Stops the autowalk if a foreign object is trapped between a pallet and the comb.

11.Pallet sag safety device

Stops the autowalk before the pallets enter the comb plate when an abnormal pallet sag is detected

12.Phase failure (phase-reversal) prevention

The autowalk operation is automatically stopped if phase failure or phase-reversal occurs.

13.Pallet missing device

Stops the autowalk if pallets are missing.

14.Handrail speed delay sensing device

Stops the autowalk if the handrail speed becomes slower than the pallet speed by more than the preset value.

15.Brake releasing sensing device

Monitor brake releasing.Autowalks can not be started if brake has not released

Optional safety devices

16.Skirt guards

The guards are coated with a slippery fluoroplastic to enhance safety.

17.Fire shutter interlocked device

Stops the autowalk when the interlocked fire shutter, which is located near the autowalk is activated.

18.Broken handrail safety device

Stops the autowalk if either handrail is broken.

19.Auxiliary brake (For inclined autowalks only)

A mechanically-operated auxiliary brake stops the autowalk when the governor is activated. (Standard for $H>6m$; Optional for $H\leq 6m$)

20.Tandem operation interlock

Should any one of the autowalks in a continuous sequence stop, all the interlocked autowalks are stopped. These autowalks are electrically interlocked to run in the same direction.

21.Braking Distance monitor device

Locked the Escalator if exceeding the maximum permitted stopping distances by more than 20%.

22.Opened floor plate safety device

Stops the Escalator if the floor plate is opened or removed.

Note: Necessary safety devices shall be installed according to the applied code.

Layout of Autowalk Horizontal Type

Model S1000

(Interior Panel: Slim, Frame or Panel Type)

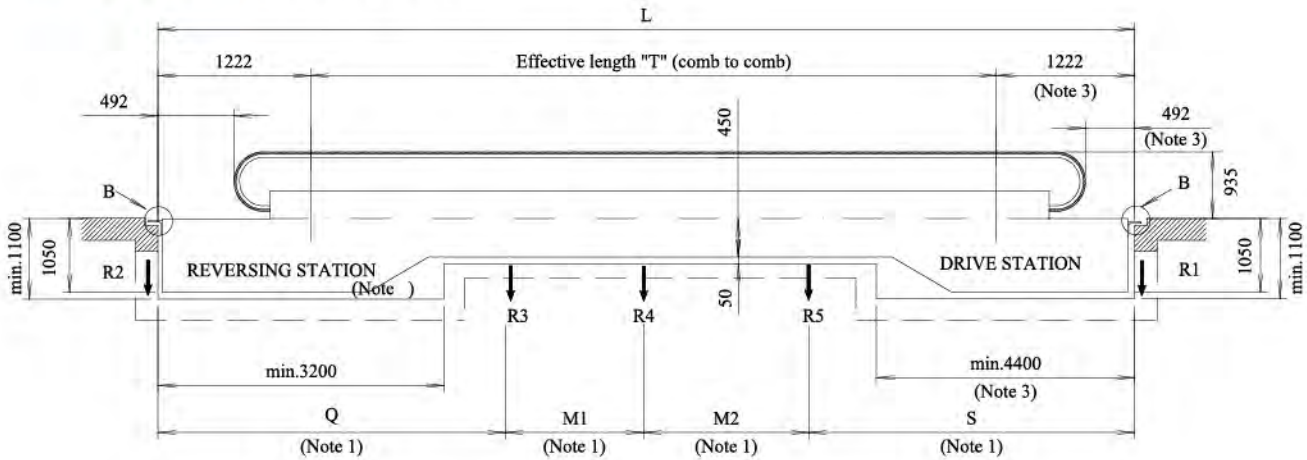

Pit Opening

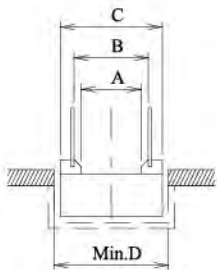

Detail B

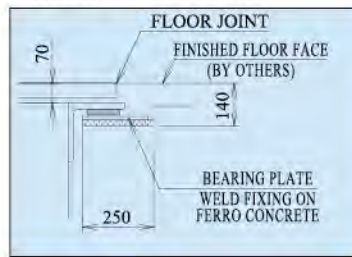

CONCRETE SUPPORT BEAM

Detail B

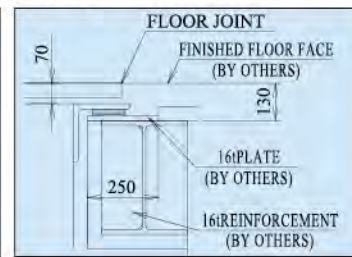

IRON FRAME SUPPORT BEAM

| Model | S1000 |
|-------|-------|
| A | 1000 |
| B | 1238 |
| C | 1550 |
| D | 1650 |

Notes:

1) Max. Q, S, M1 and M2 is in 10000mm.

2) Max. T, is 30m(S Type); 100m(F/P Type).

3) Add 300mm in case of energy saving system.

Reactions (KN)

| Model | Intermediate supports | R1 | R2 | R3 | R4 | R5 |
|-------|-----------------------|-----------------------|---------------------|----------------------------|----------------------|----------------------|
| S1000 | 1 | | | $4.71(S+Q)+22.55/S+8.65/Q$ | | |
| | 2 | $4.71S+14.92-22.55/S$ | $4.71Q+6.56-8.65/Q$ | | $4.71(S+M1)+22.55/S$ | |
| | 3 | | | $4.71(Q+M1)+8.65/Q$ | $4.71(M1+M2)$ | $4.71(S+M2)+22.55/S$ |

Note:

Q, S, M1 and M2 are in meters.

Layout of Autowalk Horizontal Type

Model S1400

(Interior Panel: Frame or Panel Type)

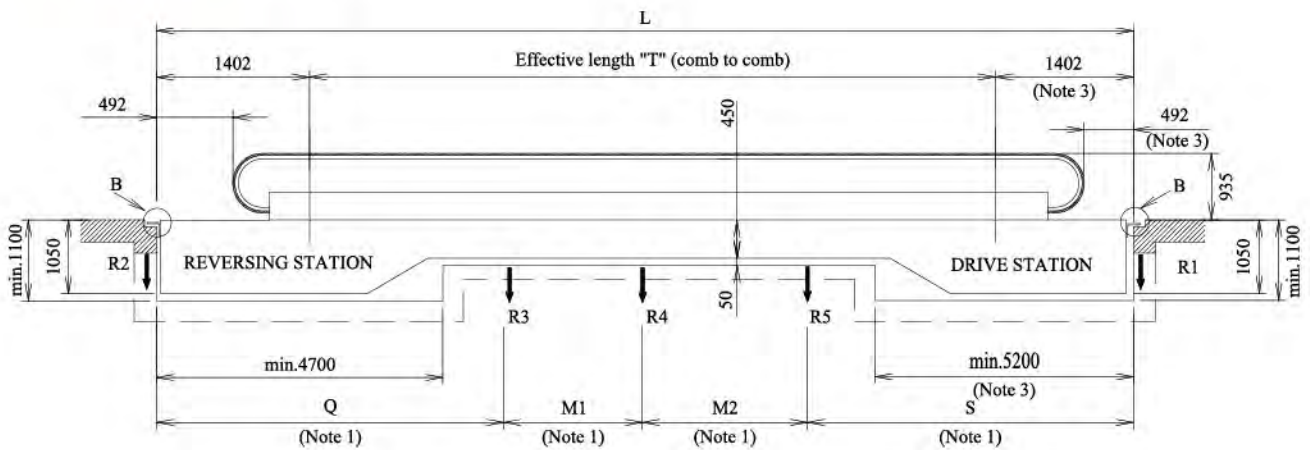

Pit Opening

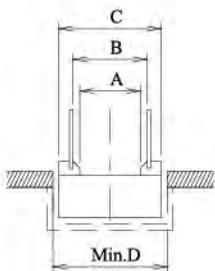

Detail B

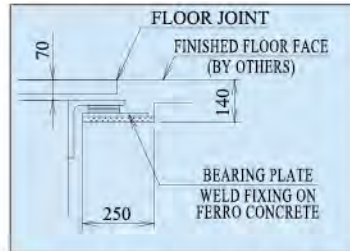

CONCRETE SUPPORT BEAM

Detail B

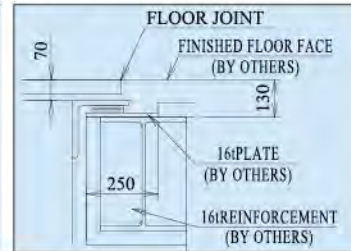

IRON FRAME SUPPORT BEAM

| Model | S1400 |
|-------|-------|
| A | 1400 |
| B | 1638 |
| C | 1950 |
| D | 2050 |

Notes:

1) Max. Q, S, M1 and M2 is in 9000mm.

2) Max. T, is 30m(S Type); 100m(F/P Type).

Reactions (KN)

| Model | Intermediate supports | R1 | R2 | R3 | R4 | R5 |
|--------|-----------------------|-----------------------|----------------------|-----------------------------|----------------------|----------------------|
| S'1400 | 1 | | | $6.34(S+Q)+29.51/S+14.03/Q$ | | |
| | 2 | $6.34S+18.47-29.51/S$ | $6.34Q+7.90-14.03/Q$ | | $6.34(S+M1)+29.51/S$ | |
| | 3 | | | $6.34(Q+M1)+14.03/Q$ | $6.34(M1+M2)$ | $6.34(S+M2)+29.51/S$ |

Note:

Q, S, M1 and M2 are in meters.

FUJITEC

<http://www.fujitec.com>